

5. Designs using NAAMM FP-1001 Specification for Design Loads of Metal Flagpoles.
6. Subject to the limitations of 1606.1.1.1, 1606.1.4, and 1606.1.6, the provisions of the FC&PA Guide to Concrete Masonry Residential Construction in High Wind Areas shall be permitted for applicable concrete masonry buildings of Group R3 occupancy for a basic wind speed of 130 mph (58 m/s) or less in Exposure B and 110 mph (49 m/s) or less in Exposure C in accordance with Figure 1606 and Section 1606.1.8.
7. ANSI/TIA/EIA 222 shall be permitted for communication tower and steel antenna support structures and shall meet the wind loads of ASCE 7 and shall be designed by a qualified engineer.
8. Subject to the limitations of 1606.1.1.1, 1606.1.4, and 1606.1.6, the provisions of the WPPC Guide to Wood Construction in High Wind Areas shall be permitted for applicable wood-frame buildings of Group R3 occupancy for a basic wind speed of 130 mph (58 m/s) or less in Exposure B and 110 mph (49 m/s) or less in Exposure C in accordance with Figure 1606 and Section 1606.1.8.

SECTION 1606 WIND LOADS

1606.1 Applications. Buildings, structures and parts thereof shall be designed to withstand the minimum wind loads prescribed herein. Decreases in wind loads shall not be made for the effect of shielding by other structures. Wind pressures shall be assumed to come from any horizontal direction and to act normal to the surfaces considered.

1606.1.1 Determination of wind forces. Wind forces on every building or structure shall be determined by the provisions of Chapter 6 of ASCE 7.

Exceptions:

1. Provisions of 1606.2 shall be permitted for buildings 60 ft (18.3 m) high or less.
2. Wind tunnel tests together with applicable sections of 1606.2.
3. Subject to the limitations of 1606.1.1.1, 1606.1.4, and 1606.1.6, the provisions of SBCCI SSTD 10 shall be permitted for applicable Group R2 and R3 buildings for a basic wind speed of 130 mph (58 m/s) or less in Exposure B and 110 mph (49 m/s) or less in Exposure C in accordance with Figure 1606 and Section 1606.1.8.
4. Subject to the limitations of 1606.1.1.1, 1606.1.4, and 1606.1.6, Provisions of AF&PA Wood Frame Construction Manual for One- and Two-Family Dwellings – 1995 SBC High Wind Edition 1996 shall be permitted for applicable wood framed buildings of Group R3 occupancy for a basic wind speed of 146 mph (65 m/s) or less in Exposure B and 124 mph (55 m/s) or less in Exposure C in accordance with Figure 1606 and Section 1606.1.8.

1606.1.1.1 Applicability. The provisions of SSTD 10, the AF&PA Wood Frame Construction Manual for One- and Two-Family Dwellings, High Wind Edition, the Guide to Concrete Masonry Residential Construction in High Wind Areas, and the WPPC Guide to Wood Construction in High Wind Areas are applicable only to buildings located within Exposure A, B or C as defined in 1606.1.8. The provisions shall not apply to buildings sited on the upper half of an isolated hill, ridge, or escarpment meeting the following conditions:

1. The hill, ridge or escarpment is 60 feet (18.3 m) or higher if located in exposure B or 30 feet (9.1 m) or higher if located in exposure C;
2. The maximum average slope of the hill exceeds 10 percent; and
3. The hill, ridge or escarpment is unobstructed upwind by other such topographic features for a distance from the high point of 50 times the height of the hill or 1 mile (1.6 km), whichever is greater.

1606.1.2 Minimum wind loads. The wind loads used in the design of the main wind-force-resisting system shall not be less than 10 pounds per square foot (0.479 kN/m²) multiplied by the area of the building or structure projected on a vertical plane normal to the wind direction. In the calculation of design wind loads for components and cladding for buildings, the algebraic sum of the pressures acting on opposite faces shall be taken into account. The design pressure for components and cladding of buildings shall not be less than 10 pounds per square foot (0.479 kN/m²) acting in either direction normal to the surface. The design force for open buildings and other structures shall not be less than 10 pounds per square foot (0.479 kN/m²) multiplied by the area A_f .

1606.1.3 Anchorage against overturning, uplift and sliding. Structural members and systems, and components and cladding in a building or structure shall be anchored to resist wind-induced overturning, uplift and sliding and to provide continuous load paths for these forces to the foundation. Where a portion of the resistance to these forces is provided by dead load, the minimum dead load likely to be in place during a design wind event shall be used.

1606.1.4 Protection of openings. In windborne debris regions, exterior glazing that receives positive pressure in the lower 60 feet (18.3 m) in buildings shall be assumed to be openings unless such glazing is impact resistant or protected with an impact resistant covering meeting the requirements of SSTD 12, ASTM E 1886 and ASTM E 1996, or Miami-Dade PA 201, 202 and 203 referenced therein as follows:

1. Glazed openings located within 30 feet (9.1 m) of grade shall meet the requirements of the Large Missile Test.
2. Glazed openings located more than 30 feet (9.1 m) above grade shall meet the provisions of the Small Missile Test.

Exception: Wood structural panels with a minimum thickness of $\frac{7}{16}$ inch (11.1 mm) and maximum panel span of 8 feet (2438 mm) shall be permitted for opening protection in one- and two-story buildings. Panels shall be pre-cut to cover the glazed openings with attachment hardware provided. Attachments shall be designed to resist the components and cladding loads determined in accordance with Table 1606.2B. Attachment in accordance with Table 1606.1.4 is permitted for buildings with mean roof height of 33 feet (10 m) or less where wind speeds do not exceed 130 mph (58 m/s).

1606.1.4.1 Buildings with openings. Where exterior glazing is assumed to be an opening, in accordance with 1606.1.4, the building shall be evaluated to determine whether the openings are of sufficient area to constitute an open or partially enclosed building as defined in 1606.1.5. Open and partially enclosed buildings shall comply with the applicable provisions of ASCE 7.

1606.1.4.2 The wind-borne debris regions requirements shall not apply landward of the designated contour line in Figure 1606. A geographical boundary that coincides with the contour line shall be established.

1606.1.5 Definitions. The following definitions apply only to the provisions of 1606.

Building, Enclosed. A building that does not comply with the requirements for open or partially enclosed buildings.

Building And Other Structure, Flexible. Slender buildings and other structures that have a fundamental natural frequency less than 1 Hz.

Building, Low-rise. Enclosed or partially enclosed buildings which comply with the following conditions:

1. mean roof height, h, less than or equal to 60 ft (18 m);
2. mean roof height, h, does not exceed least horizontal dimension.

Building, Open. A building having each wall at least 80% open. This condition is expressed for each wall by the formula $A_o \geq 0.8 A_g$ where:

A_o = total area of openings in a wall that receives positive external pressure, in sq ft (m²)

TABLE 1606.1.4
WIND-BORNE DEBRIS PROTECTION FASTENING SCHEDULE
FOR WOOD STRUCTURAL PANELS

FASTENER TYPE	FASTENER SPACING (in.) ^{1,2}			
	Panel Span ≤ 2 ft	2 ft < Panel Span < 4 ft	4 ft < Panel Span < 6 ft	6 ft < Panel Span < 8 ft
2 1/2 #6 Wood Screw ³	16	16	12	9
2 1/2 #8 Wood Screws ³	16	16	16	12
Double-Headed Nails ⁴	12	6	4	3

SI: 1 inch=25.4 mm 1 foot=305 mm

Notes:

1. This table is based on a maximum wind speed of 130 mph (58 m/s) and mean roof height of 33 feet (10 m) or less.
2. Fasteners shall be installed at opposing ends of the wood structural panel.
3. Where screws are attached to masonry or masonry/stucco, they shall be attached using vibration-resistant anchors having a minimum withdrawal capacity of 490 lb (2180 kN).
4. Nails shall be 10d common or 12d box double-headed nails.

A_g = the gross area of that wall in which A_o is identified, in sq ft (m^2)

Building, Partially Enclosed. A building which complies with both of the following conditions:

1. the total area of openings in a wall that receives positive external pressure exceeds the sum of the areas of openings in the balance of the building envelope (walls and roof) by more than 10%, and
2. the total area of openings in a wall that receives positive external pressure exceeds 4 sq ft ($0.37 m^2$) or 1% of the area of that wall, whichever is smaller, and the percentage of openings in the balance of the building envelope does not exceed 20%.

These conditions are expressed by the following formulas:

1. $A_o > 1.10A_{oi}$
2. $A_o > 4 \text{ sq ft } (0.37 m^2) \text{ or } > 0.01A_g$, whichever is smaller, and $A_{oi} / A_{gi} \leq 0.20$

where:

A_o, A_g are as defined for Open Building

A_{oi} = the sum of the areas of openings in the building envelope (walls and roof) not including A_o , in sq ft (m^2)

A_{gi} = the sum of the gross surface areas of the building envelope (walls and roof) not including A_g , in sq ft (m^2)

Building, simple diaphragm: A building which complies with all of the following conditions:

1. enclosed building,
2. mean roof height, h, less than or equal to 60 ft (18 m),
3. mean roof height, h, does not exceed least horizontal dimension,
4. building has an approximately symmetrical cross section,
5. building has no expansion joints or structural separations within the building,
6. wind loads are transmitted through floor and roof diaphragms to the vertical lateral-force-resisting systems, and
7. if the building has moment-resisting frames, roof slopes do not exceed 30%.

Components and Cladding. Elements of the building envelope that do not qualify as part of the main wind-force resisting system.

Effective Wind Area. For component and cladding elements, the effective wind area in Tables 1606.2B and 1606.2C is the span length multiplied by an effective width that need not be less than one-third the span length. For cladding fasteners, the effective wind area shall not be greater than the area that is tributary to an individual fastener.

Hurricane Prone Regions. Areas vulnerable to hurricanes defined as:

1. the U.S. Atlantic Ocean and Gulf of Mexico coasts where the basic wind speed is greater than 90 mph (40 m/s), and
2. Hawaii, Puerto Rico, Guam, Virgin Islands and American Samoa.

Importance Factor, I. A factor that accounts for the degree of hazard to human life and damage to property.

Mean Roof Height. The dimension from grade to the average of the roof eave height and the highest point on the roof surface, except that eave height shall be used for roof angle of less than or equal to 10%.

Main Wind-force Resisting System. An assemblage of structural elements assigned to provide support and stability for the overall structure. The system generally receives wind loading from more than one surface.

Wind-Borne Debris Region.

1. Areas within one mile (1.6 km) of the coastal mean high water line where the basic wind speed is 110 mph (49 m/s) or greater.
2. Areas where the basic wind speed is 120 mph (53 m/s) or greater except from the eastern border of Franklin County to the Florida-Alabama line where the region includes areas only within 1 mile of the coast.

1606.1.6 Basic wind speed. The basic wind speed in miles per hour, for the development of wind loads, shall be determined from Figure 1606. Basic wind speed for the special wind regions indicated, near mountainous terrain and near gorges shall be in accordance with local jurisdiction requirements. The exact location of wind speed lines shall be established by local ordinance using recognized physical landmarks such as major roads, canals, rivers and lake shores, wherever possible.

1606.1.6.1 Wind speed conversion. When referenced documents are based on fastest mile wind speeds, the three second gust wind velocities of Figure 1606 shall be converted to fastest mile wind velocities using Table 1606.1.6.1.

**TABLE 1606.1.6.1
EQUIVALENT BASIC WIND SPEEDS**

3 sec. gust	85	90	100	105	110	120	125	130	140	145	150
fastest mile	70	75	80	85	90	100	105	110	120	125	130

1 mph = 0.447 m/s

1606.1.7 Information on drawings. The following information related to wind loads shall be shown on the construction drawings:

1. Basic wind speed, mph, (m/s).

2. Wind importance factor (I) and building category.
3. Wind exposure - if more than one wind exposure is used, the wind exposure and applicable wind direction shall be indicated.
4. The applicable internal pressure coefficient.
5. Components and Cladding. The design wind pressures in terms of psf (kN/m²), to be used for the design of exterior component and cladding materials not specifically designed by the registered design professional.

1606.1.8 Exposure Category. For each wind direction considered, an exposure category that adequately reflects the characteristics of ground surface irregularities shall be determined for the site at which the building or structure is to be constructed. For a site located in the transition zone between categories, the category resulting in the largest wind forces shall apply. Account shall be taken of variations in ground surface roughness that arise from natural topography and vegetation as well as from constructed features. For any given wind direction, the exposure in which a specific building or other structure is sited shall be assessed as being one of the following categories:

1. **Exposure A.** Large city centers with at least 50% of the buildings having a height in excess of 70 feet (21.3 m). Use of this exposure category shall be limited to those areas for which terrain representative of Exposure A prevails in the upwind direction for a distance of at least one-half mile (0.8 km) or 10 times the height of the building or other structure, whichever is greater. Possible channeling effects or increased velocity pressures caused by the building or structure being located in the wake of adjacent buildings shall be taken into account.
2. **Exposure B.** Urban and suburban areas, wooded areas, or other terrain with numerous closely spaced obstructions having the size of single-family dwellings or larger. Exposure B shall be assumed unless the site meets the definition of another type exposure.
3. **Exposure C.** Means, except in the high velocity hurricane zone, that area which lies within 1500 feet of the coastal construction control line, or within 1500 feet of the mean high tide line, whichever is less. On barrier islands, exposure category C shall be applicable in the coastal building zone set forth in s. 161.55(5), Florida Statutes.
4. **Exposure D.** Flat, unobstructed areas exposed to wind flowing over open water (excluding shorelines in hurricane prone regions) for a distance of at least 1 mile (1.61 km). Shorelines in Exposure D include inland waterways, the Great Lakes and coastal areas of California, Oregon, Washington and Alaska. This exposure shall apply only to those buildings and other structures exposed to the wind coming from

over the water. Exposure D extends inland from the shoreline a distance of 1500 feet (460 m) or 10 times the height of the building or structure, whichever is greater.

1606.2 Simplified provisions for Low Rise Buildings

1606.2.1 Scope. Procedures in 1606.2 shall be used for determining and applying wind pressures in the design of simple diaphragm buildings with flat, hipped and gable-shaped roofs having a mean roof height not exceeding the least horizontal dimension of the building or 60 ft (18.3 m), whichever is less.

The provisions of 1606.2 shall not be used if any of the following conditions exist:

1. Buildings on which exterior glazing is considered to be openings in accordance with 1606.1.4.
2. Buildings sited on the upper half of an isolated hill or escarpment meeting all the following conditions:
 - 2.1 The hill or escarpment is 60 feet (18.3 m) or higher if located in exposure B or 30 feet (9.1 m) or higher if located in Exposure C.
 - 2.2 The maximum average slope of the hill exceeds 10 percent.
 - 2.3 The hill or escarpment is unobstructed upwind by other such topographic features for a distance from the high point of 50 times the height of the hill or 1 mile (1.6 km), whichever is less.

1606.2.2 Wind pressures

1606.2.2.1 Structural members, cladding, fasteners and systems providing for the structural integrity of the building shall be designed for the loads from Tables 1606.2A, 1602.2B and 1602.2C using Figure 1606, multiplied by the appropriate height and exposure coefficient from Table 1606.2D and the importance factor from Table 1606.

FIGURE 1606

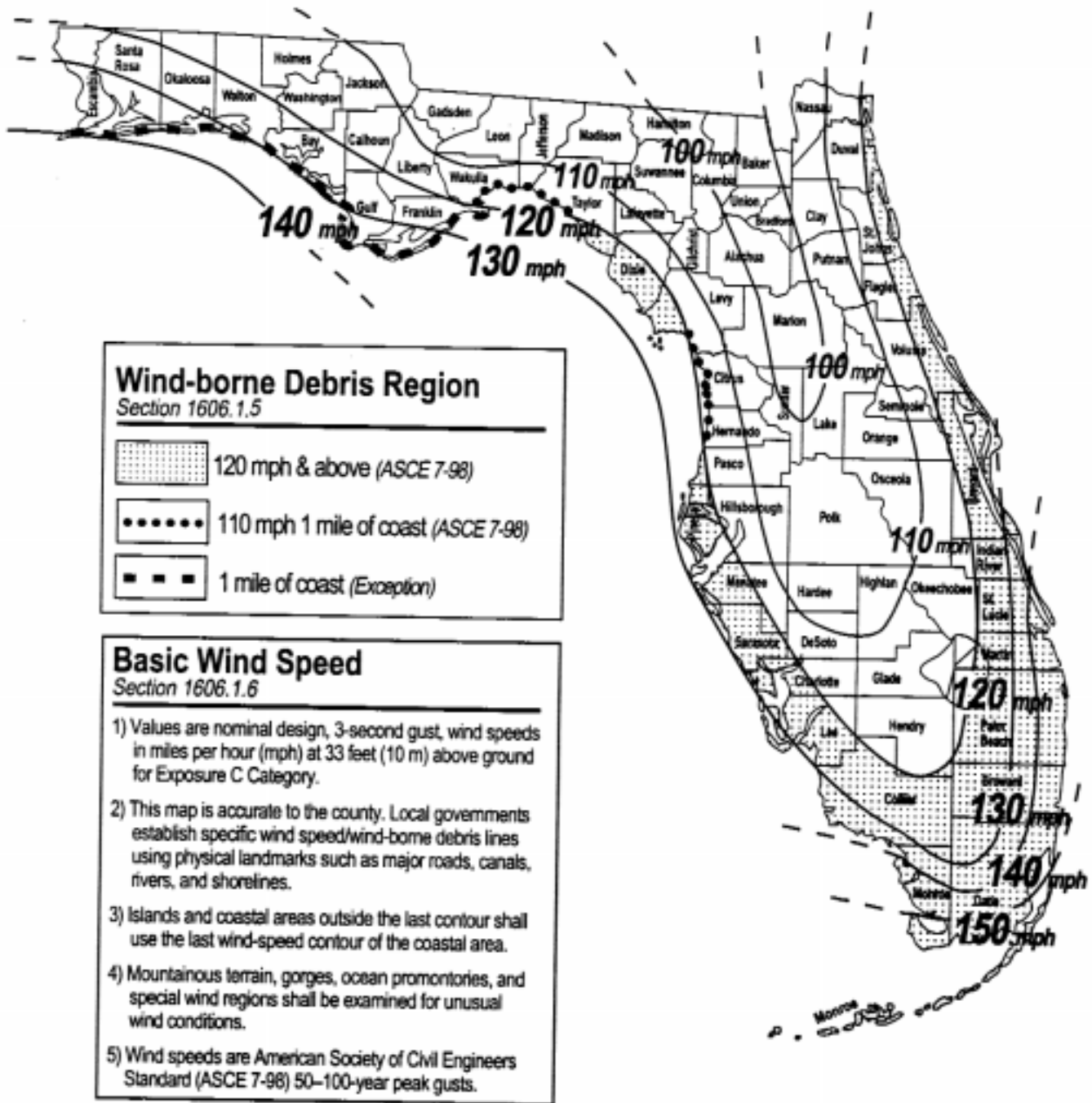

FIGURE 1606
STATE OF FLORIDA
WIND-BORNE DEBRIS REGION & BASIC WIND SPEED

**TABLE 1606
IMPORTANCE FACTORS FOR BUILDINGS AND
OTHER STRUCTURES**

Nature of Occupancy	Importance Factor I_w
All buildings and structures except those listed below	1.0
Buildings and structures where the occupant load is 300 or more in any one room.	1.15
Buildings and structures designated as essential facilities, including, but not limited to: (1) Hospital and other medical facilities having surgery or emergency treatment areas (2) Fire or rescue and police stations (3) Primary communication facilities and disaster operation centers (4) Power stations and other utilities required in an emergency	1.15
Buildings and structures that represent a low hazard to human life in the event of failure, such as agricultural buildings, screen enclosures, certain temporary facilities, and minor storage facilities	0.87 ^a

^a In hurricane-prone regions with $V > 100$ mph (45 m/s), I_w shall be 0.77.

1606.2.2.2 Members that act as both part of the main wind-force-resisting system and as components and cladding shall be designed for each separate load case.

1606.2.3 Edge strips and end zones. The width of the edge strips (a), as shown in Figure 1606.2 (c), shall be 10% of the least horizontal dimension or 40% of the eave height, whichever is less but not less than either 4% of the least horizontal dimension or 3 feet (914 mm). End zones as shown in Figure 1606.2b shall be twice the width of the edge strip (a).

1606.2.4 Main wind force resisting system (MWFRS). All elements and connections of the MWFRS shall be designed for vertical and horizontal loads based on the combined leeward and windward wall pressures and roof pressures determined from Table 1606.2A. Pressures shall be applied in accordance with the loading diagrams shown in Figure 1606.2a to the end zone and interior zone as shown in Figure 1606.2b. The building shall be designed for all wind directions. For buildings having flat roofs, a ridge line normal to the wind direction shall be assumed at the mid-length dimension of the roof for all directions considered. Each corner shall be considered in turn as the windward corner.

1606.2.4.1 Overhang loads. The pressures to be used for the effects of roof overhangs on MWFRS shall be taken from Table 1606.2A and include the effect of the wind on both the bottom and top surfaces.

1606.2.5 Components and cladding. Pressure for wind loading actions on components and cladding shall be determined from Table 1606.2B for enclosed portions of the building and Table 1606.2C for overhangs, based on the effective area for the element under consideration. The

pressures in Table 1606.2C include internal pressure. The pressure shall be applied in accordance with the loading diagrams in Figure 1606.2c.

1606.3 Roof systems

1606.3.1 Roof deck. The roof deck shall be designed to withstand the wind pressures determined from the provisions of 1606.2 for buildings with a mean roof height not exceeding 60 ft (18.3 m) in height or 1606.1.1 for buildings of any height.

1606.3.2 Roof coverings. Roof coverings shall comply with 1606.3.1. Rigid tile roof coverings that are air-permeable and installed over a roof deck shall be permitted to be designed in accordance with 1606.3.3.

Exception: Rigid tile roof coverings that are air permeable and installed over a roof deck complying with 1606.3.1 may be designed in accordance with 1606.6.3.

1606.3.3 Rigid tile. Wind loads on rigid tile roof coverings shall be determined in accordance with the following formula:

$$M_a = q_h C_L b L L_a [1.0 - GC_p]$$

where:

M_a = aerodynamic uplift moment acting to raise the tail of the tile, foot-pounds (N-mm).

q_h = wind velocity pressure determined from Equation 6-1 of ASCE 7 (psf).

C_L = The lift coefficient shall be 0.2 or shall be determined by testing in accordance with 1707.5.

b = exposed width of the roof tile, feet (mm).

L = length of the roof tile, feet (mm).

L_a = moment arm [feet (mm)] from the axis of rotation to the point of uplift on the roof tile. The point of uplift shall be taken at 0.76 L from the head of the tile and the middle of the exposed width. For roof tiles with nails or screws (with or without a tail clip), the axis of rotation shall be taken as the head of the tile for direct deck applications and as the top edge of the batten for battened applications. For roof tiles fastened only by a nail or screw along the side of the tile, the axis of rotation shall be determined by testing. For roof tiles installed with battens and fastened only by a clip near the tail of the tile, the moment arm shall be determined about the top edge of the batten with consideration given for the point of rotation of the tiles

TABLE 1606.2A
MAIN WIND FORCE RESISTING SYSTEM WIND LOADS FOR A BUILDING WITH A MEAN ROOF HEIGHT OF 30 FEET LOCATED IN Exposure B

Wind Velocity (mph)	Load Direction	Roof angle (degrees)	Horizontal loads ²						Vertical Loads (psf)						Max. Horizontal Wall Loads ⁴ (psf)			
			End Zone		Interior Zone		End Zone		Interior Zone		Windward Overhang		Zone		1E	4E	1	4
			Wall	Roof ³	Wall	Roof ³	Windward Roof	Leeward Roof	Windward Roof	Leeward Roof	End Zone	Interior Zone	End Zone	Interior Zone				
90	Transverse	0 - 5	12.8	-6.7	8.5	-4.0	-15.4	-8.8	-10.7	-10.7	-6.8	-21.6	-16.9	10.0	-7.5	7.2	-5.8	
			17.8	-4.7	11.9	-2.6	-15.4	-10.7	-10.7	-10.7	-8.1	-21.6	-16.9	12.0	-10.1	8.8	-7.5	
		30 < angle ≤ 45	14.4	9.9	11.5	7.9	5.6	-8.8	4.8	-7.5	-5.1	-5.8	11.0	-5.8	11.0	-8.1	9.1	-6.8
100	Longitudinal	All angles	12.8	-6.7	8.5	-4.0	-15.4	-8.8	-10.7	-10.7	-6.8	-21.6	-16.9	10.0	-7.5	7.2	-5.8	
			15.9	-8.2	10.5	-4.9	-19.1	-10.8	-13.3	-13.3	-8.4	-26.7	-20.9	12.0	-9.3	8.8	-7.2	
		20	22.0	-5.8	14.6	-3.2	-19.1	-13.3	-13.3	-10.1	-26.7	-20.9	15.0	-12.5	10.8	-9.3		
110	Transverse	0 - 5	17.8	12.2	14.2	9.8	6.9	-10.8	5.9	-9.3	-6.3	-7.2	13.0	-10.1	11.3	-8.4		
			15.9	-8.2	10.5	-4.9	-19.1	-10.8	-13.3	-13.3	-8.4	-26.7	-20.9	12.0	-9.3	8.8	-7.2	
		30 < angle ≤ 45	19.2	-10.0	12.7	-5.9	-23.1	-13.1	-16.0	-16.0	-10.1	-32.3	-25.3	15.0	-11.3	10.7	-8.7	
120	Longitudinal	All angles	26.6	-7.0	17.7	-3.9	-23.1	-16.0	-16.0	-12.2	-32.3	-25.3	18.0	-15.1	13.1	-11.3		
			21.6	14.8	17.2	11.8	8.3	-13.1	7.2	-11.3	7.6	-8.7	16.0	-12.2	13.7	-10.1		
		30 < angle ≤ 45	19.2	-10.0	12.7	-5.9	-23.1	-13.1	-16.0	-16.0	-10.1	-32.3	-25.3	15.0	-11.3	10.7	-8.7	
130	Transverse	0 - 5	22.8	-11.9	15.1	-7.0	-27.4	-15.6	-19.1	-12.1	-38.4	-30.1	17.0	-13.4	12.7	-10.3		
			31.6	-8.3	21.1	-4.6	-27.4	-19.1	-19.1	-14.5	-38.4	-30.1	22.0	-18.0	15.6	-13.4		
		30 < angle ≤ 45	25.7	17.6	20.4	14.0	9.9	-15.6	8.6	-13.4	-9.0	-10.3	19.0	-14.5	16.2	-12.1		
140	Longitudinal	All angles	22.8	-11.9	15.1	-7.0	-27.4	-15.6	-19.1	-12.1	-38.4	-30.1	17.0	-13.4	12.7	-10.3		
			26.8	-13.9	17.8	-8.2	-32.2	-18.3	-22.4	-14.2	-45.1	-35.3	20.0	-15.7	14.9	-12.1		
		30 < angle ≤ 45	30.1	20.6	24.0	16.5	11.6	-18.3	10.0	-15.7	-10.6	-12.1	22.0	-17.0	19.1	-14.2		
150	Transverse	0 - 5	31.1	-16.1	20.6	-9.6	-37.3	-21.2	-26.0	-16.4	-52.3	-40.9	24.0	-18.2	17.3	-14.0		
			43.0	-11.4	28.7	-6.3	-37.3	-26.0	-26.0	-19.7	-52.3	-40.9	29.0	-24.5	21.2	-18.2		
		30 < angle ≤ 45	35.0	23.9	27.8	19.1	13.4	-21.2	11.7	-18.2	-12.3	-14.0	26.0	-19.7	22.1	-16.4		
160	Longitudinal	All angles	31.1	-16.1	20.6	-9.6	-37.3	-21.2	-26.0	-16.4	-52.3	-40.9	24.0	-18.2	17.3	-14.0		
			35.7	-18.5	23.7	-11.0	-42.9	-24.4	-29.8	-18.9	-60.0	-47.0	27.0	-20.9	19.9	-16.1		
		30 < angle ≤ 45	49.4	-13.0	32.9	-7.2	-42.9	-29.8	-29.8	-22.6	-60.0	-47.0	34.0	-28.1	24.4	-20.9		
170	Longitudinal	All angles	40.1	27.4	31.9	22.0	15.4	-24.4	13.4	-20.9	-14.1	-16.1	30.0	-22.6	25.4	-18.9		
			35.7	-18.5	23.7	-11.0	-42.9	-24.4	-29.8	-18.9	-60.0	-47.0	27.0	-20.9	19.9	-16.1		
		30 < angle ≤ 45	40.1	27.4	31.9	22.0	15.4	-24.4	13.4	-20.9	-14.1	-16.1	30.0	-22.6	25.4	-18.9		

For SI: 1 ft² = 0.0929 m², 1 mph = 0.447 m/s, 1 degree of angle = 0.01745 rad, 1 psf = 47.88 N/m².

- Notes:**
- 1 Pressures for roof angles from 5 to 20 degrees shall be interpolated from the table.
 - 2 Pressures are the sum of the windward and leeward pressures and shall be applied to the windward elevation of the building in accordance with Figure 1606.2(c).
 - 3 If pressure is less than 0, use 0.
 - 4 Pressures shall be applied in accordance with Figure 1606.2(b).

**TABLE 1606.2B
COMPONENT AND CLADDING WIND LOADS FOR A BUILDING WITH A MEAN ROOF HEIGHT
OF 30 FEET LOCATED IN EXPOSURE B (psf)**

Zone ³	Effective wind area (ft ²)	Basic Wind Speed V (mph - 3 second gust)															
		85		90		100		110		120		130		140		150	
Roof Angle > 0-10 degrees																	
1	10.0	10.0	-13.0	10.0	-14.6	10.0	-18.0	10.0	-21.8	10.5	-25.9	12.4	-30.4	14.3	-35.3	16.5	-40.5
1	20.0	10.0	-12.7	10.0	-14.2	10.0	-17.5	10.0	-21.2	10.0	-25.2	11.6	-29.6	13.4	-34.4	15.4	-39.4
1	50.0	10.0	-12.2	10.0	-13.7	10.0	-16.9	10.0	-20.5	10.0	-24.4	10.6	-28.6	12.3	-33.2	14.1	-38.1
1	100.0	10.0	-11.9	10.0	-13.3	10.0	-16.5	10.0	-19.9	10.0	-23.7	10.0	-27.8	11.4	-32.3	13.0	-37.0
2	10.0	10.0	-21.8	10.0	-24.4	10.0	-30.2	10.0	-36.5	10.5	-43.5	12.4	-51.0	14.3	-59.2	16.5	-67.9
2	20.0	10.0	-19.5	10.0	-21.8	10.0	-27.0	10.0	-32.6	10.0	-38.8	11.6	-45.6	13.4	-52.9	15.4	-60.7
2	50.0	10.0	-16.4	10.0	-18.4	10.0	-22.7	10.0	-27.5	10.0	-32.7	10.6	-38.4	12.3	-44.5	14.1	-51.1
2	100.0	10.0	-14.1	10.0	-15.8	10.0	-19.5	10.0	-28.1	10.0	-33.0	11.4	-38.2	11.4	-38.2	13.0	-43.9
3	10.0	10.0	-32.8	10.0	-36.8	10.0	-45.4	10.0	-55.0	10.5	-65.4	12.4	-76.8	14.3	-89.0	16.5	-102.2
3	20.0	10.0	-27.2	10.0	-30.5	10.0	-37.6	10.0	-45.5	10.0	-54.2	11.6	-63.6	13.4	-73.8	15.4	-84.7
3	50.0	10.0	-19.7	10.0	-22.1	10.0	-27.3	10.0	-33.1	10.0	-39.3	10.6	-46.2	12.3	-53.5	14.1	-61.5
3	100.0	10.0	-14.1	10.0	-15.8	10.0	-19.5	10.0	-23.6	10.0	-28.1	10.0	-33.0	11.4	-38.2	13.0	-43.9
Roof Angle > 10-30 degrees																	
1	10.0	10.0	-11.9	10.0	-13.3	10.4	-16.5	12.5	-19.9	14.9	-23.7	17.5	-27.8	20.3	-32.3	23.3	-37.0
1	20.0	10.0	-11.6	10.0	-13.0	10.0	-16.0	11.4	-19.4	13.6	-23.0	16.0	-27.0	18.5	-31.4	21.3	-36.0
1	50.0	10.0	-11.1	10.0	-12.5	10.0	-15.4	10.0	-18.6	11.9	-22.2	13.9	-26.0	16.1	-30.2	18.5	-34.6
1	100.0	10.0	-10.8	10.0	-12.1	10.0	-14.9	10.0	-18.1	10.5	-21.5	12.4	-25.2	14.3	-29.3	16.5	-33.6
2	10.0	10.0	-25.1	10.0	-28.2	10.4	-34.8	12.5	-42.1	14.9	-50.1	17.5	-58.7	20.3	-68.1	23.3	-78.2
2	20.0	10.0	-22.8	10.0	-25.6	10.0	-31.5	11.4	-38.2	13.6	-45.4	16.0	-53.3	18.5	-61.8	21.3	-71.0
2	50.0	10.0	-19.7	10.0	-22.1	10.0	-27.3	10.0	-33.0	11.9	-39.3	13.9	-46.1	16.1	-53.5	18.5	-61.4
2	100.0	10.0	-17.4	10.0	-19.5	10.0	-21.1	10.0	-29.1	10.5	-34.7	12.4	-40.7	14.3	-47.2	16.5	-54.2
3	10.0	10.0	-25.1	10.0	-28.2	10.4	-34.8	12.5	-42.1	14.9	-50.1	17.5	-58.7	20.3	-68.1	23.3	-78.2
3	20.0	10.0	-22.8	10.0	-25.6	10.0	-31.5	11.4	-38.2	13.6	-45.4	16.0	-53.3	18.5	-61.8	21.3	-71.0
3	50.0	10.0	-19.7	10.0	-22.1	10.0	-27.3	10.0	-33.0	11.9	-39.3	13.9	-46.1	16.1	-53.5	18.5	-61.4
3	100.0	10.0	-17.4	10.0	-19.5	10.0	-24.1	10.0	-29.1	10.5	-34.7	12.4	-40.7	14.3	-47.2	16.5	-54.2
Roof Angle > 30-45 degrees																	
1	10.0	11.9	-13.0	13.3	-14.6	16.5	-18.0	19.9	-21.8	23.7	-25.9	27.8	-30.4	32.3	-35.3	37.0	-40.5
1	20.0	11.6	-12.3	13.0	-13.8	16.0	-17.1	19.4	-20.7	23.0	-24.6	27.0	-28.9	31.4	-33.5	36.0	-38.4
1	50.0	11.1	-11.5	12.5	-12.8	15.4	-15.9	18.6	-19.2	22.2	-22.8	26.0	-26.8	30.2	-31.1	34.6	-35.7
1	100.0	10.8	-10.8	12.1	-12.1	14.9	-14.9	18.1	-18.1	21.5	-21.5	25.2	-25.2	29.3	-29.3	33.6	-33.6
2	10.0	11.9	-15.2	13.3	-17.0	16.5	-21.0	19.9	-25.5	23.7	-30.3	27.8	-35.6	32.3	-41.2	37.0	-47.3
2	20.0	11.6	-14.5	13.0	-16.3	16.0	-20.1	19.4	-24.3	23.0	-29.0	27.0	-34.0	31.4	-39.4	36.0	-45.3
2	50.0	11.1	-13.7	12.5	-15.3	15.4	-18.9	18.6	-22.9	22.2	-27.2	26.0	-32.0	30.2	-37.1	34.6	-42.5
2	100.0	10.8	-13.0	12.1	-14.6	14.9	-18.0	18.1	-21.8	21.5	-25.9	25.2	-30.4	29.3	-35.3	33.6	-40.5
3	10.0	11.9	-15.2	13.3	-17.0	16.5	-21.0	19.9	-25.5	23.7	-30.3	27.8	-35.6	32.3	-41.2	37.0	-47.3
3	20.0	11.6	-14.5	13.0	-16.3	16.0	-20.1	19.4	-24.3	23.0	-29.0	27.0	-34.0	31.4	-39.4	36.0	-45.3
3	50.0	11.1	-13.7	12.5	-15.3	15.4	-18.9	18.6	-22.9	22.2	-27.2	26.0	-32.0	30.2	-37.1	34.6	-42.5
3	100.0	10.8	-13.0	12.1	-14.6	14.9	-18.0	18.1	-21.8	21.5	-25.9	25.2	-30.4	29.3	-35.3	33.6	-40.5
Wall																	
4	10.0	13.0	-14.1	14.6	-15.8	18.0	-19.5	21.8	-23.6	25.9	-28.1	30.4	-33.0	35.3	-38.2	40.5	-43.9
4	20.0	12.4	-13.5	13.9	-15.1	17.2	-18.7	20.8	-22.6	24.7	-26.9	29.0	-31.6	33.7	-36.7	38.7	-42.1
4	50.0	11.6	-12.7	13.0	-14.3	16.1	-17.6	19.5	-21.3	23.2	-25.4	27.2	-29.8	31.6	-34.6	36.2	-39.7
4	100.0	11.1	-12.2	12.4	-13.6	15.3	-16.8	18.5	-20.4	22.0	-24.2	25.9	-28.4	30.0	-33.0	34.4	-37.8
5	10.0	13.0	-17.4	14.6	-19.5	18.0	-24.1	21.8	-29.1	25.9	-34.7	30.4	-40.7	35.3	-47.2	40.5	-54.2
5	20.0	12.4	-16.2	13.9	-18.2	17.2	-22.5	20.8	-27.2	24.7	-32.4	29.0	-38.0	33.7	-44.0	38.7	-50.5
5	50.0	11.6	-14.7	13.0	-16.5	16.1	-20.3	19.5	-24.6	23.2	-29.3	27.2	-34.3	31.6	-39.8	36.2	-45.7
5	100.0	11.1	-13.5	12.4	-15.1	15.3	-18.7	18.5	-22.6	22.0	-26.9	25.9	-31.6	30.0	-36.7	34.4	-42.1

For SI: 1 ft² = 0.0929 m², 1 mph = 0.447 m/s, 1 psf = 47.88 N/m².

- 1 For effective areas or wind speeds between those given above the load may be interpolated, otherwise use the load associated with the lower effective area.
- 2 Table values shall be adjusted for height and exposure by multiplying by adjustment coefficients in Table 1606.2D.
- 3 See Figure 1606.2(c) for location of zones.
- 4 Plus and minus signs signify pressures acting toward and away from the building surfaces.

**TABLE 1606.2C
ROOF OVERHANG COMPONENT AND CLADDING DESIGN WIND PRESSURES
FOR A BUILDING WITH MEAN ROOF HEIGHT OF 30 FEET LOCATED IN
EXPOSURE B (psf)**

Zone	Effective Wind Area (ft ²)	Basic Wind Speed v (mph - 3 second gust)						
		90	100	110	120	130	140	150
Roof Angle > 0-10 degrees								
2	10	-21.0	-25.9	-31.4	-37.3	-43.8	-50.8	-58.3
2	20	-20.6	-25.5	-30.8	-36.7	-43.0	-49.9	-57.3
2	100	-19.8	-24.4	-29.5	-35.1	-41.2	-47.8	-54.9
3	10	-34.6	-42.7	-51.6	-61.5	-72.1	-83.7	-96.0
3	20	-27.1	-33.5	-40.5	-48.3	-56.6	-65.7	-75.4
3	100	-10.0	-12.2	-14.8	-17.6	-20.6	-23.9	-27.4
Roof Angle > 10 - 30 degrees								
2	10	-27.2	-33.5	-40.6	-48.3	-56.7	-65.7	-75.5
2	20	-27.2	-33.5	-40.6	-48.3	-56.7	-65.7	-75.5
2	100	-27.2	-33.5	-40.6	-48.3	-56.7	-65.7	-75.5
3	10	-45.7	-56.4	-68.3	-81.2	-95.3	-110.6	-126.9
3	20	-40.5	-50.0	-60.5	-72.0	-84.5	-98.0	-112.5
3	100	-28.4	-35.1	-42.4	-50.5	-59.3	-68.7	-78.9
Roof Angle > 30 - 45 degrees								
2	10	-24.7	-30.5	-36.9	-43.9	-51.5	-59.8	-68.6
2	20	-24.0	-29.6	-35.8	-42.6	-50.0	-58.0	-66.5
2	100	-22.2	-27.4	-33.2	-39.5	-46.4	-53.8	-61.7
3	10	-24.7	-30.5	-36.9	-43.9	-51.5	-59.8	-68.6
3	20	-24.0	-29.6	-35.8	-42.6	-50.0	-58.0	-66.5
3	100	-22.2	-27.4	-33.2	-39.5	-46.4	-53.8	-61.7

For SI: 1 psf = 47.88 N/m², 1 ft² = 0.0929 m², 1 mph = 0.447 m/s.

Note: For effective areas between those given above the load may be interpolated, otherwise use the load associated with the lower effective area.

**TABLE 1606.2D
HEIGHT AND EXPOSURE ADJUSTMENT COEFFICIENTS**

Mean Roof Height	Exposure		
	B	C	D
15	1.00	1.21	1.47
20	1.00	1.29	1.55
25	1.00	1.35	1.61
30	1.00	1.40	1.66
35	1.05	1.45	1.70
40	1.09	1.49	1.74
45	1.12	1.53	1.78
50	1.16	1.56	1.81
55	1.19	1.59	1.84
60	1.22	1.62	1.87

Note: All table values shall be adjusted for other exposures and heights by multiplying by the above coefficients.

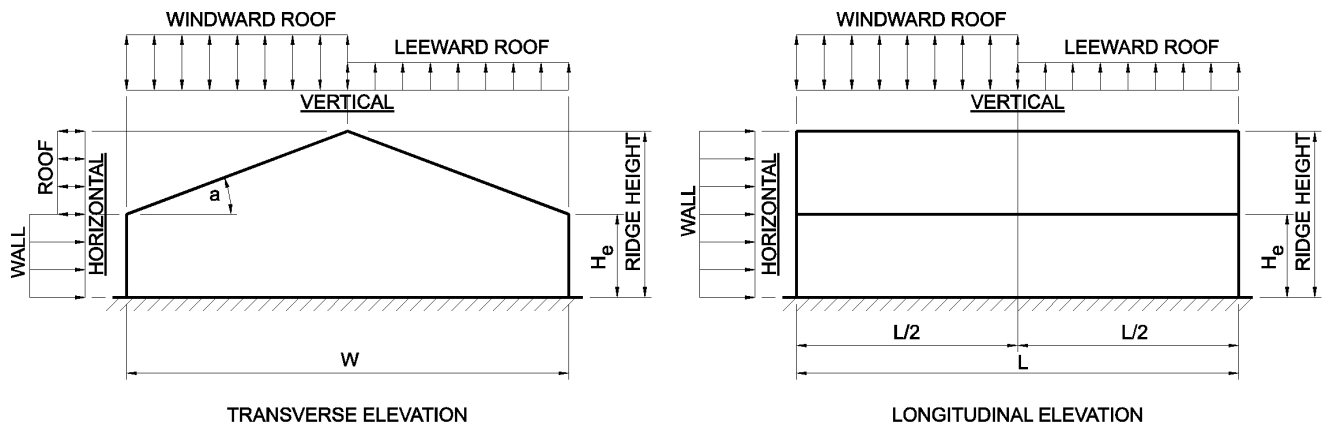

FIGURE 1606.2a
APPLICATION OF MAIN WIND FORCE RESISTING SYSTEM
LOADS FOR SIMPLE DIAPHRAGM BUILDINGS

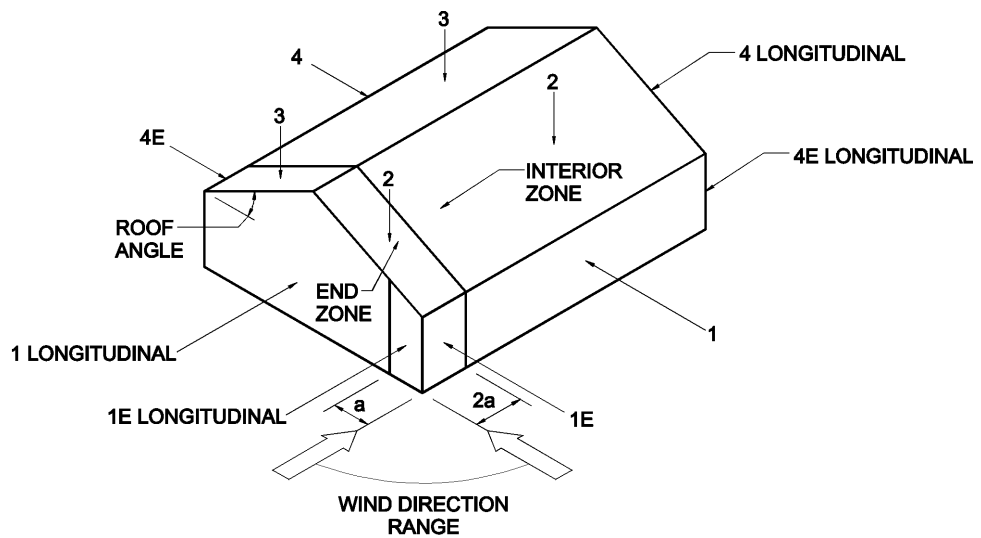
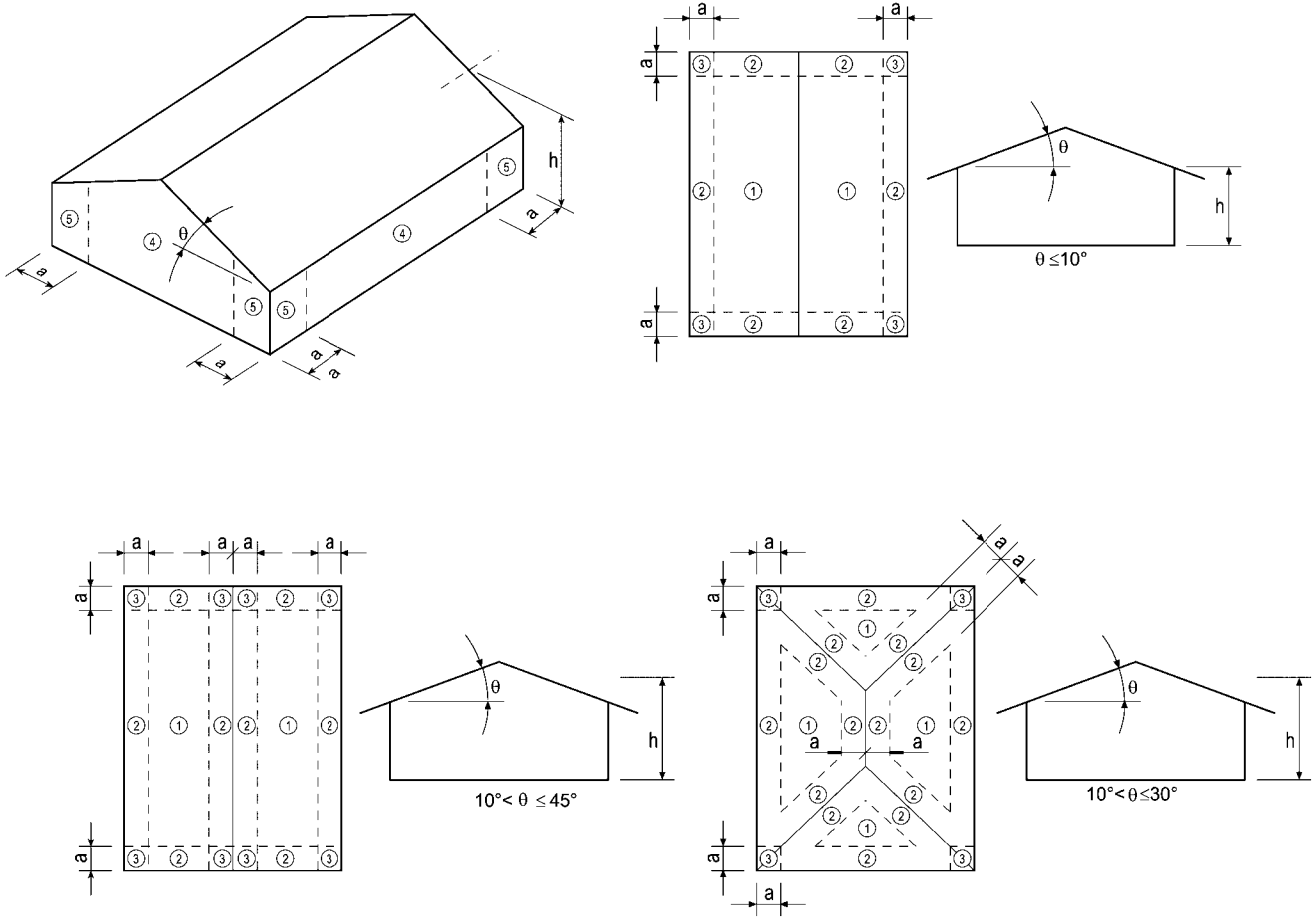

FIGURE 1606.2b
MAIN WIND FORCE LOADING DIAGRAM

FIGURE 1609.6(2)



For SI: 1 degree = 0.01745 rad.

FIGURE 1606.2(c)
COMPONENT AND CLADDING LOADING DIAGRAMS

based on straight bond or broken bond and the tile profile.

GC_p = roof coefficient for each applicable zone determined from ASCE 7. Roof coefficient shall not be adjusted for internal pressure.

Concrete and clay roof tiles complying with the following limitations shall be designed to withstand the wind loads prescribed in this section.

1. The roof tiles shall be either loose laid on battens or mechanically fastened or mortar set or adhesive set.
2. The roof tiles shall be installed on solid sheathing which has been designed as components and cladding in accordance with 1606.2.
3. An underlayment shall be installed in accordance with 1507.4.
4. The tile shall be single lapped interlocking with a minimum head lap of not less than 2 inches (51 mm).
5. The length of the tile shall be between 1.0 and 1.75 ft (305 and 533 mm).
6. The exposed width of the tile shall be between 0.67 and 1.25 ft (203 and 381 mm).
7. Maximum thickness of the tail of the roof tile shall not exceed 1.3 inches (33 mm).
8. Roof tiles using mortar set or adhesive set systems shall have at least 2/3 of the tile's area free of mortar or adhesive contact.